

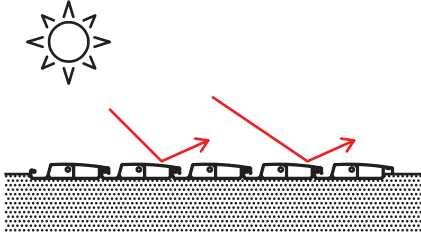

## Nozioni tecniche . Technical concepts

### FUNZIONI . FEATURES

Protezione solare  
Sun protection



Protezione solare e raffreddamento  
Sun protection and cooling

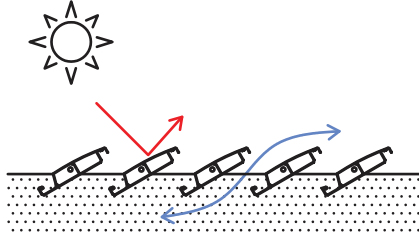

Protezione dalla pioggia  
Rain protection

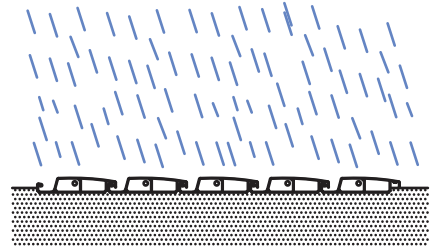

### SCHEMA DI LETTURA . READING SCHEME

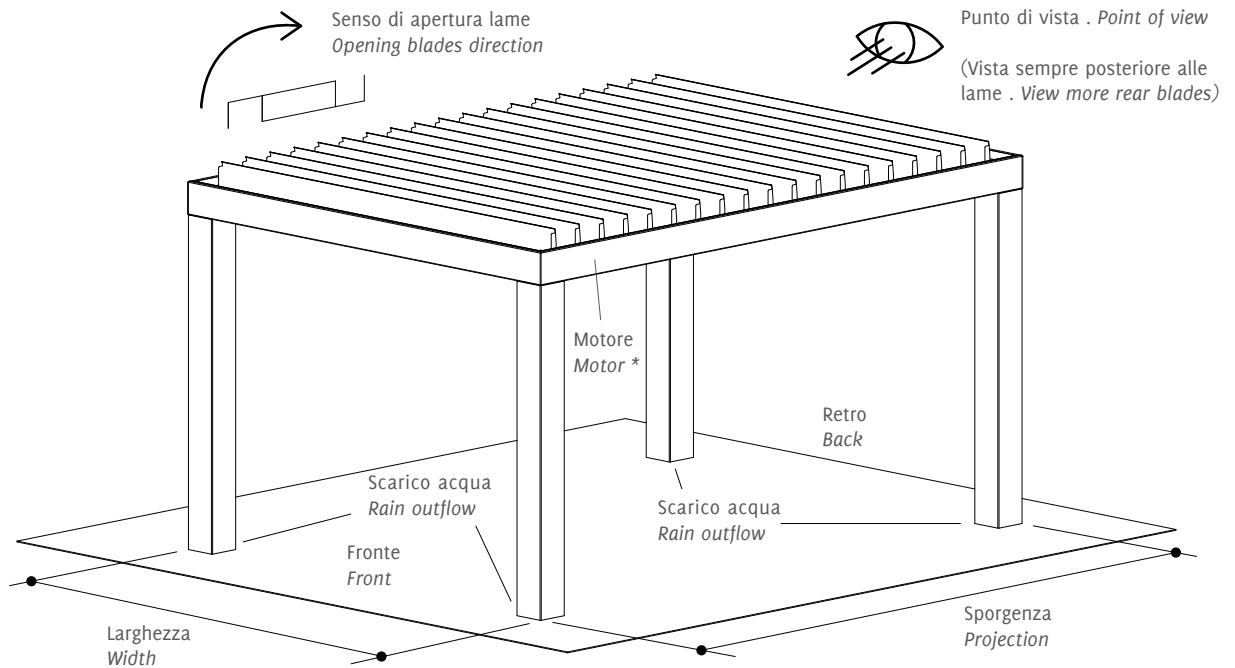

\* Esempio di motore posizionato lato sinistro rispetto il punto di vista . Example of motor situated left side respect the point of view.

### ORIENTAMENTO LAME . BLADES ORIENTATION

LUCE SOLARE DIRETTA . DIRECT SUNLIGHT  
Maggior luminosità . More luminosity

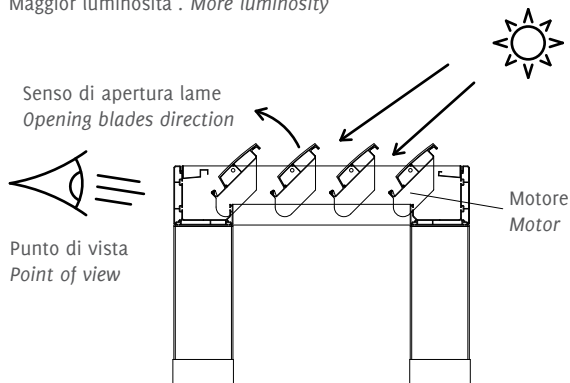

LUCE SOLARE INDIRETTA . INDIRECT SUNLIGHT  
Maggior schermatura . More solar shading

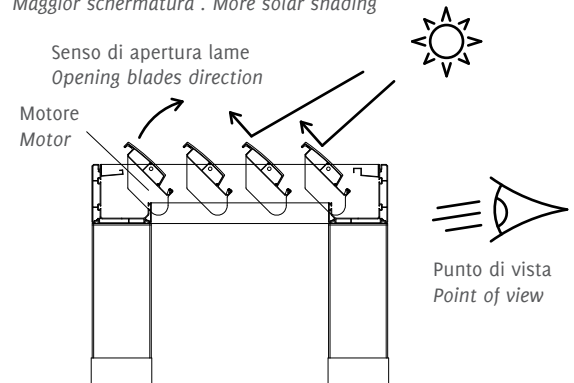





## Configurazioni . Configurations

### MONTAGGIO PERPENDICOLARE ALLA PARETE . ASSEMBLY PERPENDICULAR TO WALL

Gronda perimetrale predisposta per essere installata direttamente alla parete di supporto, per staffe a disegno chiedere preventivo . *Perimetric water-drain able to be installed directly to the wall, for brackets ask for quote.*

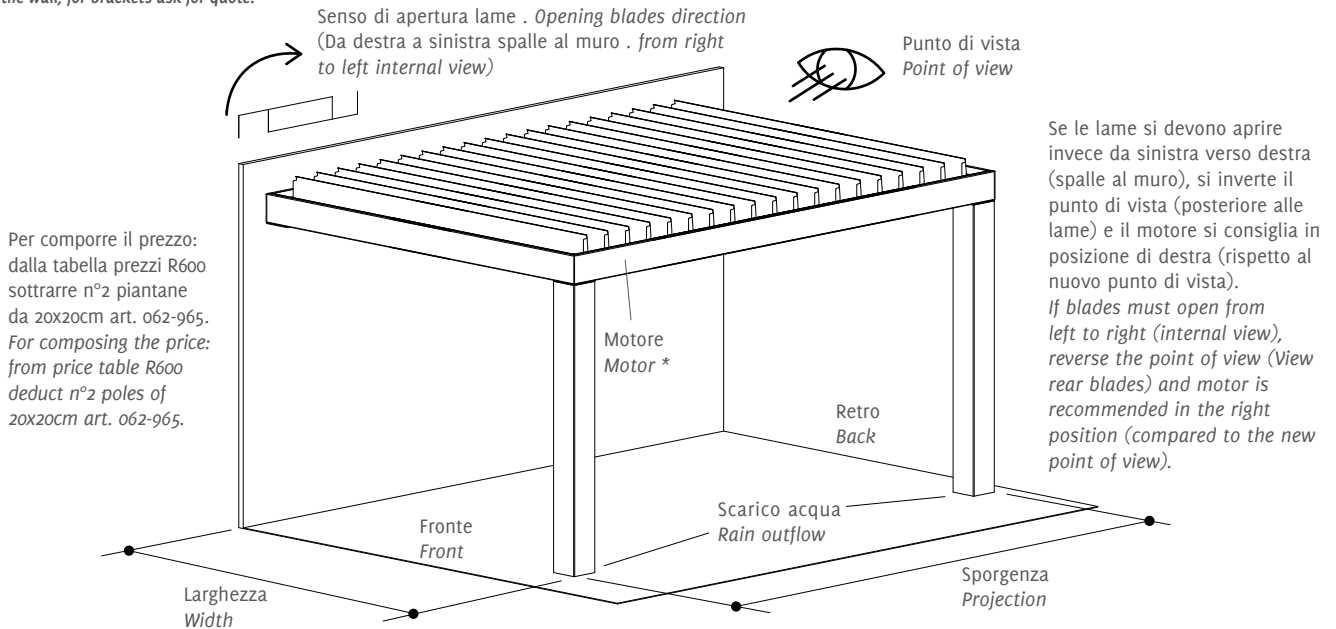

\* Esempio di motore posizionato lato sinistro dal punto di vista. Per facilitare il montaggio si consiglia di posizionare il motore dal lato opposto del muro.  
*Example of motor situated left side from point of view. For facilitating assembly we recommend positioning motor on the opposite side of the wall.*



### MONTAGGIO SU STRUTTURE ESISTENTI . MOUNTING ON EXISTING STRUCTURES

Gronda perimetrale installabile su strutture portanti (per staffe a disegno chiedere preventivo) . *Perimetric water-drain profile possible to install on structures (for brackets ask for quote)*

Per comporre il prezzo: dalla tabella prezzi R600 sottrarre n°4 piantane da 20x20cm art. 062-965.  
*For composing the price: from price table R600 deduct n°4 poles of 20x20cm art. 062-965.*

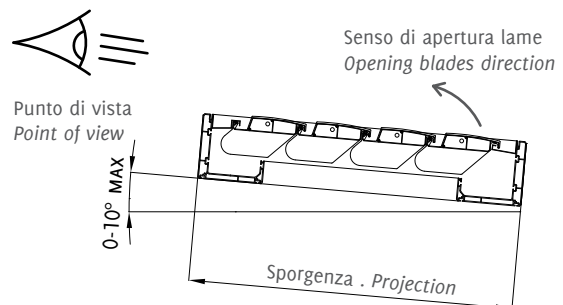
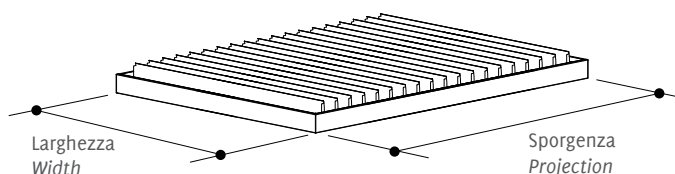

Sono necessari almeno 2 scarichi acqua . *2 rain outflow at least needed*

Inclinazione massima consentita per appoggio su strutture esistenti  
*Max allowed inclination dor installation on structures*



## Configurazioni . Configurations

### AFFIANCAMENTO LATERALE . LATERAL ADJOINING

Per comporre il prezzo: dalla tabella prezzi R600 sommare ogni singolo modulo e sottrarre il numero di piantane in comune.  
 For composing the price: from price table R600 sum each module and deduct the number of common poles.

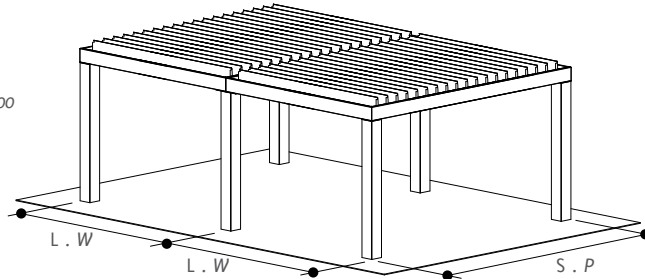

Lo schema rappresenta un affiancamento laterale con motori in posizione sinistra, ogni piantana permette lo scarico dell'acqua, comprese quelle in comune.  
 The diagram shows a lateral adjoining with motors on the left, each pole allow to drain water, including those in common.

Vista dall'alto . Top view

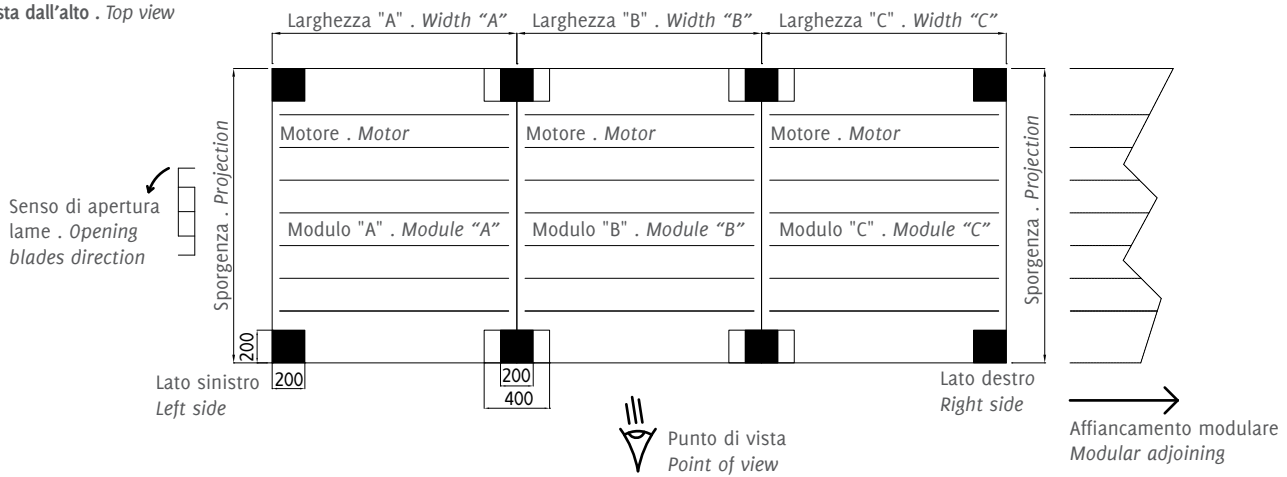

### AFFIANCAMENTO FRONTALE . FRONTAL ADJOINING

Per comporre il prezzo: dalla tabella prezzi R600 sommare ogni singolo modulo e sottrarre il numero di piantane in comune.  
 For composing the price: from price table R600 sum each module and deduct the number of common poles.

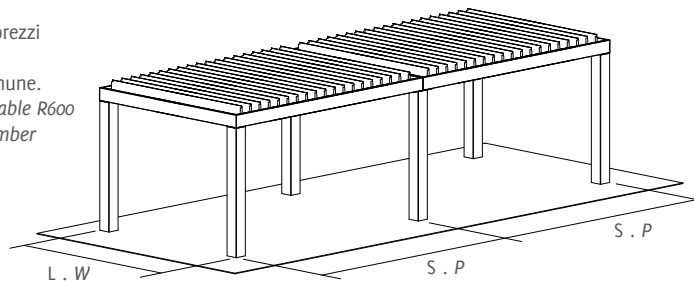

Lo schema rappresenta un affiancamento frontale con motori in posizione sinistra, ogni piantana permette lo scarico dell'acqua, comprese quelle in comune.  
 The diagram shows a frontal adjoining with motors on the left, each pole allow to drain water, including those in common.

Vista dall'alto . Top view

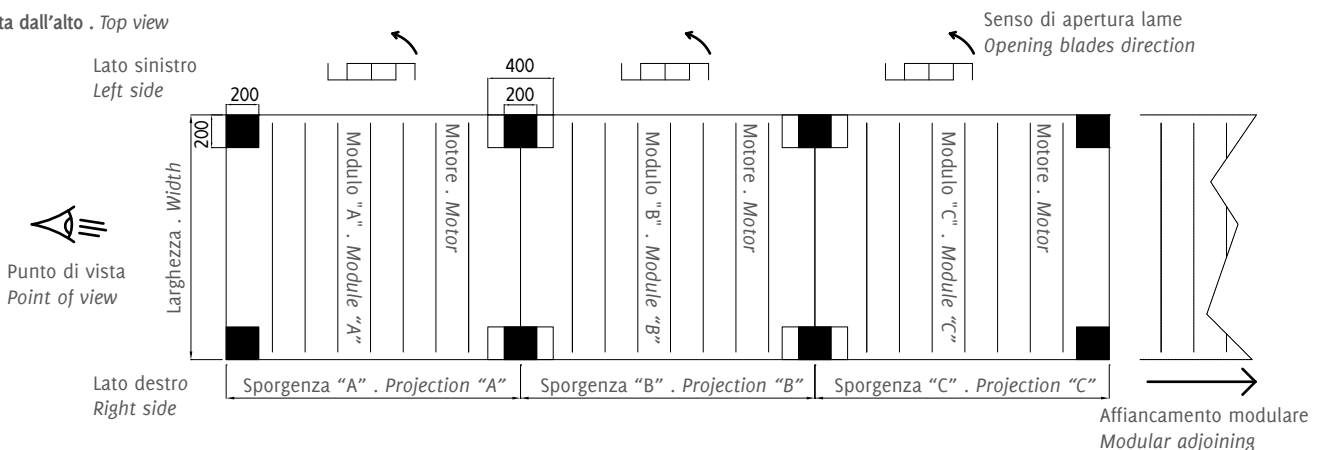



## Dati tecnici . Technical data

Quote espresse in mm - Dimensions in mm

Vista frontale . Frontal view

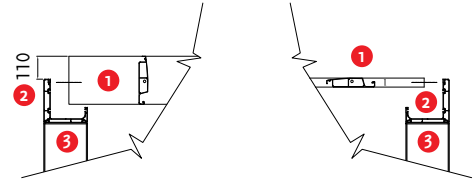
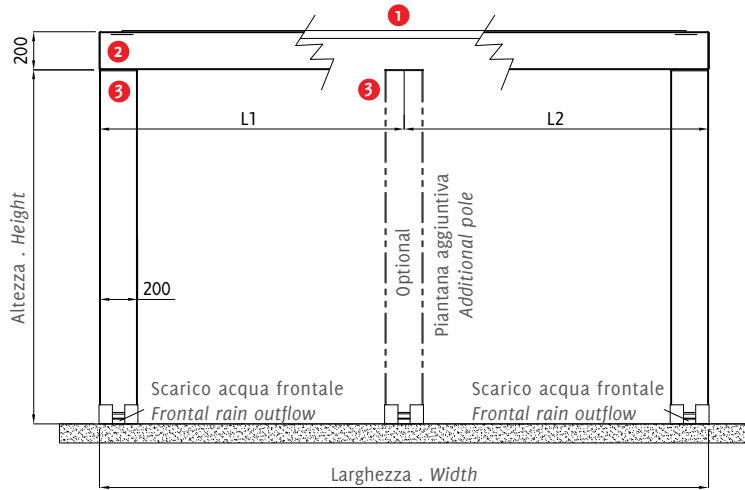

Lamelle aperte a 90°  
Opened blades at 90°

Lamelle chiuse a 0°  
Closed blades at 0°

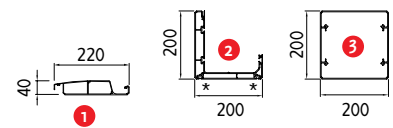

Lamelle coibentate e insonorizzate con poliuretano all'interno . Blades insulated and soundproofed with polyurethane inside

Vista laterale . Side view

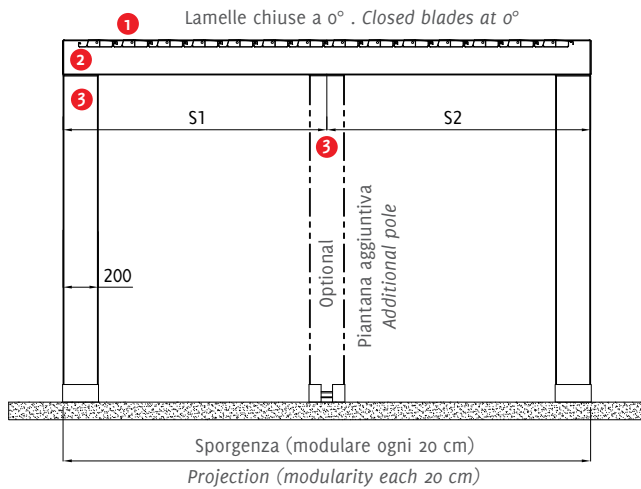

Piede a terra . Foot

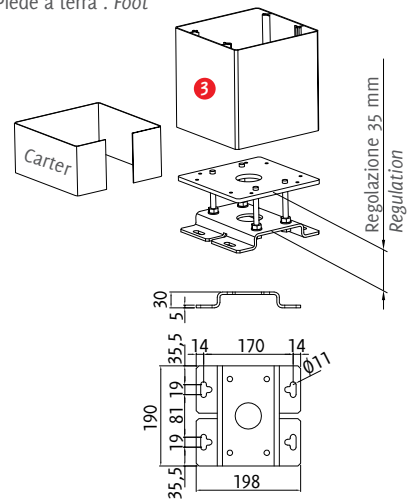

\* Sede per inserimento di luci LED o scorrevoli per teli a drappeggio . Location for inserting LED lights or sliders for drapes.

Sporgenza Projection	S cm	200	220	240	260	280	300	320	340	360	380	400	420	440	460	480	500	520	540	560	580	600
Lamelle Blades	n °	9	10	11	12	13	14	15	16	17	18	19	20	21	22	23	24	25	26	27	28	29

# R600 PERGOKLIMA

## Dettagli tecnici . Technical details

Quote espresse in mm - Dimensions in mm

Rotazione lamelle a 0° . Blades rotation at 0°

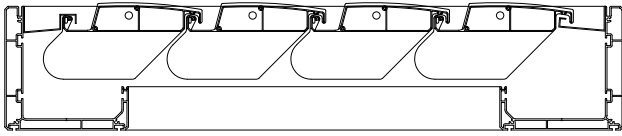

Rotazione lamelle a 45° . Blades rotation at 45°

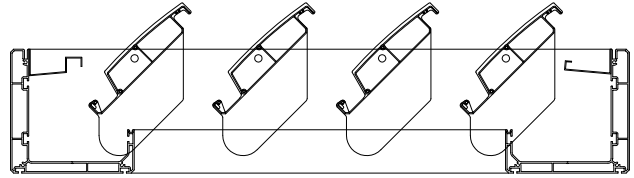

Rotazione lamelle a 90° . Blades rotation at 90°

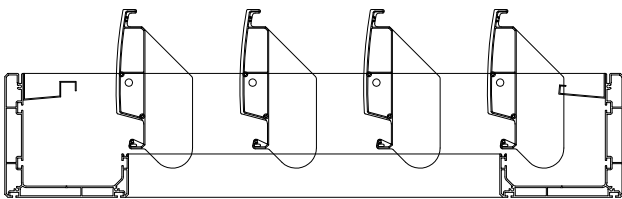

Rotazione lamelle a 140° . Blades rotation at 140°

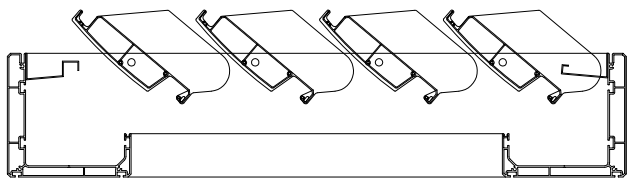

Rotazione delle lamelle a 0°, 45°, 90° e 140° preimpostate su 4 pulsanti del telecomando; possibilità di regolazioni intermedie tramite i tre pulsanti del telecomando: apertura, stop e chiusura . Rotation blades at 0°, 45°, 90° and 140° on 4 preset buttons on the remote control; possibility of intermediate adjustments using the three buttons on the remote control: opening, closing and stop.

## PIANTANA IN COMUNE PER MODULI AFFIANCATI . COMMON POLE FOR ADJOINING MODULES

Vista dall'alto . Top view

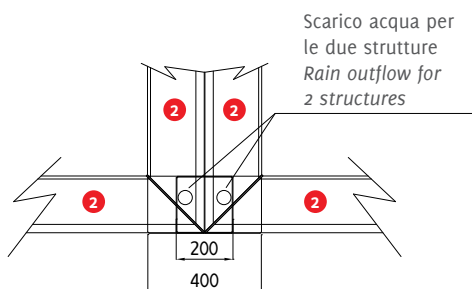

Vista laterale . Side view

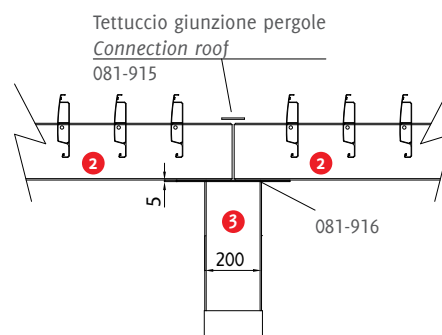

Art 081-915 di dimensioni 80x5mm consigliato anche come spessore di compensazione per eventuali chiusure perimetrali.  
Art 081-915 of dimensions 80x5mm recommended as thick compensation for any perimetric closings.

## Legenda tecnica . Technical legend

- ① Lamella . Blade
- ② Profilo gronda perimetrale . Perimetric water-drain profile
- ③ Piantana . Pole