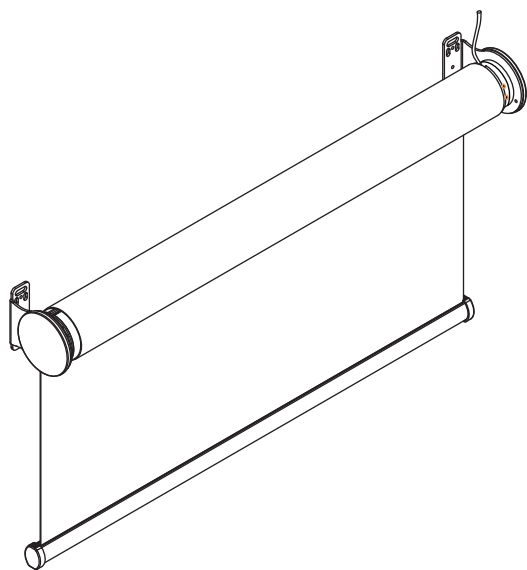
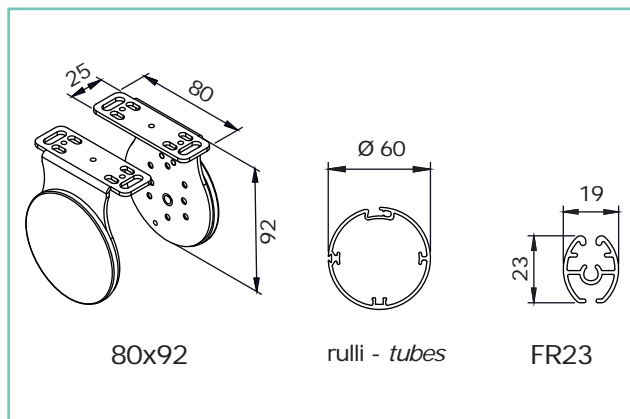
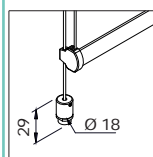
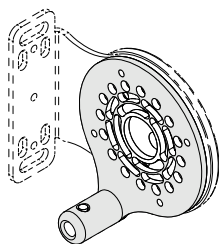

F 107 80x92 M50 motore - motor

SERIE F - F SERIES

 dimensioni in mm
 dimensions shown in mm

varianti - optional

contropiastre in ferro zincato verniciato (bianco, nero, grigio) complete di cilindro serracavo in inox AISI 304. Per versione a supplemento con cavi perlon Ø3mm o acciaio inox Ø2,5mm.

interior steel powder coated plate (white, black, grey) with stainless steel AISI 304 cable block. Available on supplement for Ø3mm perlon cable or Ø2.5 mm stainless steel cable version



tenditore per fissaggio piano orizzontale o staffe in acciaio per fissaggio al piano verticale

cable tensioning block for window sill/floor mounting or steel brackets for wall mounting

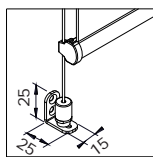

copri staffe magnetici in alluminio satinato
 satin finish aluminium magnetic bracket covers

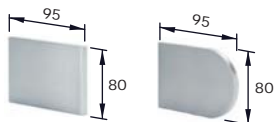
CARATTERISTICHE:

Tipo di applicazione: verticale

Ambiente di applicazione: interno

Staffe di fissaggio: 82x92 mm in ferro verniciato con copri staffe in PVC (bianco, nero, grigio). A supplemento copri staffe magnetici in alluminio satinato.

Contropiastre in ferro zincato verniciato complete di cilindro tendicavo in acciaio inox AISI 304 per versione col cavi a supplemento

Rullo di avvolgimento: Ø 60 mm in alluminio estruso con ogiva per facilitare la manutenzione del telo

Fondale: FR23 in alluminio estruso con tappi in PVC

Manovra: a motore tubolare 230V/50Hz, M50, con finecorsa salita/discesa e cavo di alimentazione

Protezione termica e indice di protezione agli spruzzi d'acqua IP44. Interruttore escluso

Fissaggio: a parete o a soffitto.

CHARACTERISTICS:

Application: vertical

Installation: indoors. Minimum width 80 cm

Brackets: 80x92 mm steel powder coated brackets with PVC covers (white, grey, black). Supplement for satin finish aluminium magnetic bracket covers. Interior steel powder coated plate (white, black, grey) with stainless steel AISI 304 cable block available on supplement for guided version with cables

Roller tube: Ø 60 mm extruded aluminum tube with slot to facilitate fabric removal

Hem bar: FR23 extruded aluminum hem bar with PVC caps

Operation: M50 230V/50Hz tubular motor with top/bottom limit switches and mains cable, thermal cut-out and class IP44 water resistance. Switch excluded

Mounting: wall or ceiling.

note - notes

la misura finita della larghezza tenda deve essere calcolata partendo dall'esterno delle staffe esclusi i copri staffe, vedi modulo d'ordine
 blind width taken excluding bracket covers, see order

motore M50 - M50 motor

la tenda motorizzata viene fornita senza interruttore
 blind supplied without switch

colori standard - standard colours

bianco Ral 9010 termolaccato - white Ral 9010
 avorio Ral 1013 termolaccato - ivory Ral 1013
 marrone Ral 8017 termolaccato - brown Ral 8017
 nero Ral 9005 termolaccato - black Ral 9005
 argento anodizzato - silver anodised

tessuti abbinabili - suitable fabrics

per l'utilizzo dei tessuti consultare la sezione dei teli confezionati e/o Tabella "A"

for fabric choice consult the fabric section and Tab. "A"

supplementi - supplement
