

F 109 110x120 M50 motore - motor

SERIE F - F SERIES

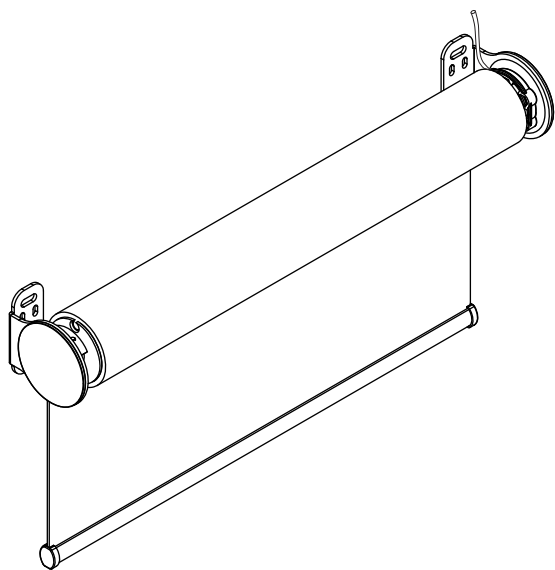

dimensioni in mm
dimensions shown in mm

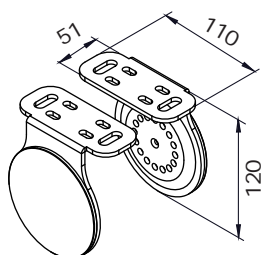

110x120

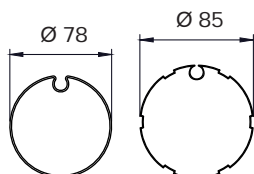

ruolo - tube

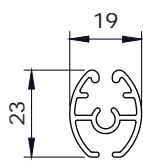

FR23

CARATTERISTICHE:

Tipo di applicazione: verticale

Ambiente di applicazione: interno

Staffe di fissaggio: 110x120 mm in ferro zincato verniciato con copri staffe in PVC (bianco, nero, grigio). A supplemento staffe 110x120 mm in acciaio inox AISI 304

Rullo di avvolgimento: Ø 78/85 mm in ferro zincato con ogiva per facilitare la manutenzione del telo

Fondale: FR23 in alluminio estruso con tappi in PVC

Manovra: a motore tubolare 230V/50Hz, M50, con finecorsa salita/discesa e cavo di alimentazione. Protezione termica e indice di protezione agli spruzzi d'acqua IP44. Interruttore escluso

Fissaggio: a parete o a soffitto.

CHARACTERISTICS:

Application: vertical

Installation: indoors. Minimum width 80 cm

Brackets: 110x120 mm steel powder coated brackets with PVC covers (white, grey, black). Supplement for 110x120mm AISI 304 stainless steel brackets

Roller tube: Ø 78/85 mm galvanized steel tube with slot to facilitate fabric removal

Hem bar: FR23 extruded aluminum hem bar with PVC caps

Operation: M50 230V/50Hz tubular motor with top/bottom limit switches and mains cable, thermal cut-out and class IP44 water resistance. Switch excluded

Mounting: wall or ceiling.

note - notes

la misura finita della larghezza tenda deve essere calcolata partendo dall'esterno delle staffe esclusi i copri staffe, vedi modulo d'ordine
blind width taken excluding bracket covers, see order

motore M50 - M50 motor

la tenda motorizzata viene fornita senza interruttore
blind supplied without switch

colori standard - standard colours

bianco Ral 9010 termolaccato - white Ral 9010
avorio Ral 1013 termolaccato - ivory Ral 1013
marrone Ral 8017 termolaccato - brown Ral 8017
nero Ral 9005 termolaccato - black Ral 9005
argento anodizzato - silver anodised

tessuti abbinabili - suitable fabrics

per l'utilizzo dei tessuti consultare la sezione dei teli confezionati e/o Tabella "A"

for fabric choice consult the fabric section and Tab. "A"

supplementi - supplement

