

Tenda a rullo con cassonetto e comando di manovra a motore. Motore tubolare monofase 230V/50Hz M40 con regolazione del fine corsa, protezione termica, indice di protezione IP44. Interruttore non fornito. Rullo di avvolgimento Ø 40 mm in alluminio estruso. Cassonetto CT76 in alluminio estruso con veletta di copertura nella parte posteriore. Coppie di testate laterali in plastica bianche e nere. Fondale FR23 in alluminio estruso con tappi in PVC.

Boxed roller blind with motorised operation. 230V/50Hz tubular motor, with top/bottom limit switches and mains cable, thermal cut-out and class IP44 water resistance. Switch excluded. Ø 40mm extruded aluminum tube. CT76 extruded aluminum headbox with backcover and black/white plastic end cheeks. FR23 extruded aluminum bottom rail with PVC end caps.

Dimensioni in mm
Dimensions shown in mm

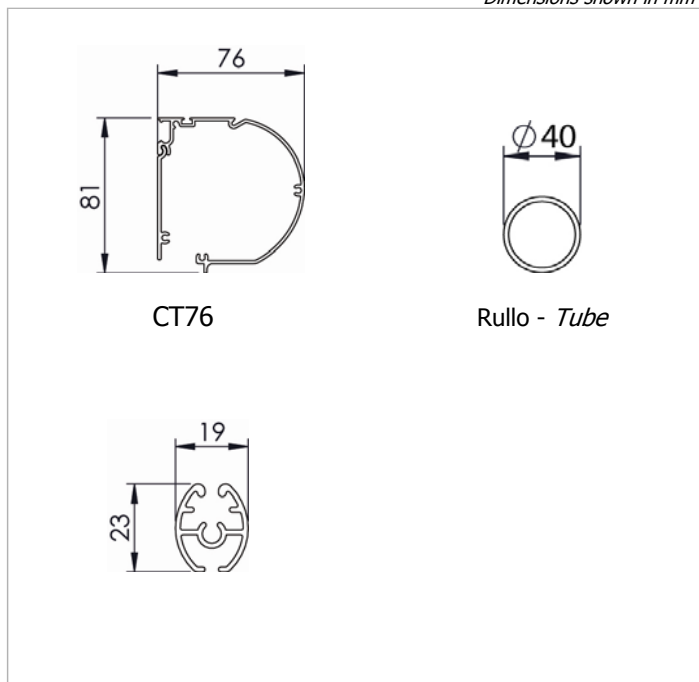

Note - Notes

Motore M40 - M40 Motor

La tenda motorizzata viene fornita senza interruttore.
Blind supplied without switch.

Colori standard - Standard colours

Bianco Ral 9010 termolaccato - *White Ral 9010*
Argento anodizzato - *Silver anodised*

Tessuti abbinabili - Suitable fabrics

Per l'utilizzo dei tessuti consultare la sezione dei teli confezionati e/o Tabella "A".

For fabric choice consult the fabric section and Tab. "A".

Supplementi - Supplement

Varianti - Optional

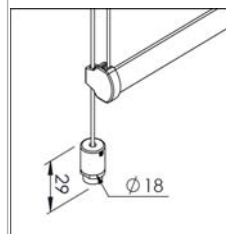

Cavo acciaio inox Ø2,5 mm con tenditore per fissaggio piano orizzontale, con staffe in acciaio per piano verticale.
Ø2.5mm stainless steel cable with cable tensioning block for window sill/floor mounting, or brackets for wall mounting.

